

LM379 Dual 6 Watt Audio Amplifier

General Description

The LM379 is a monolithic dual power amplifier which offers high quality performance for stereo phonographs, tape players, recorders, and AM-FM stereo receivers, etc.

The LM379 will deliver 6W/channel to an 8Ω load. The amplifier is designed to operate with a minimum of external components and contains an internal bias regulator to bias each amplifier. Device overload protection consists of both internal current limit and thermal shutdown. For more information, see AN-125.

Features

- A_{VO} typical 90 dB
- 6W per channel
- 70 dB ripple rejection
- 75 dB channel separation
- Internal stabilization

- Self centered biasing
- 3 MΩ input impedance
- Internal current limiting
- Internal thermal protection

Applications

- Multi-channel audio systems
- Tape recorders and players
- Movie projectors
- Automotive systems
- Stereo phonographs
- Bridge output stages
- AM-FM radio receivers
- Intercoms
- Servo amplifiers
- Instrument systems

Schematic Diagram

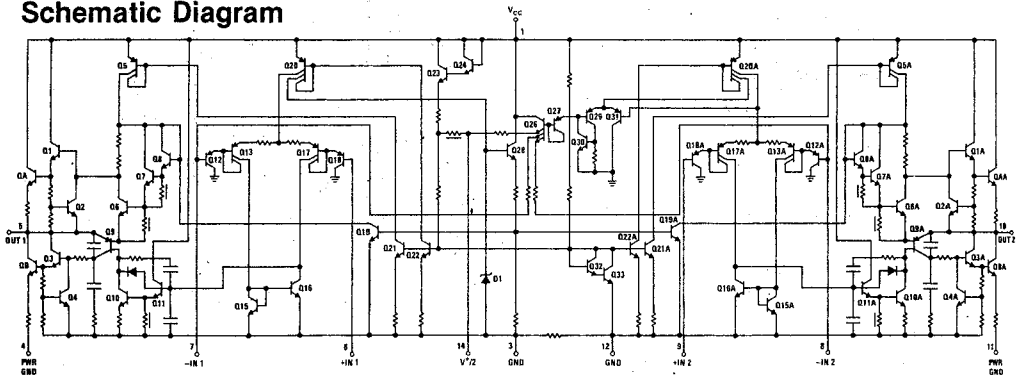

Connection Diagram

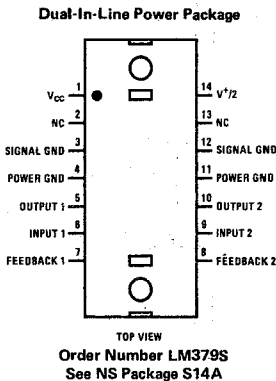

Typical Applications

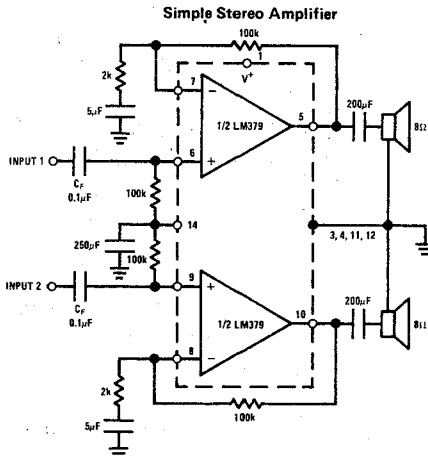

Absolute Maximum Ratings

Supply Voltage	35V
Input Voltage	0V - V_{SUPPLY}
Operating Temperature	0°C to +70°C
Storage Temperature	-65°C to +150°C
Junction Temperature	150°C
Lead Temperature (Soldering, 10 seconds)	300°C

Electrical Characteristics

$V_S = 28V$, $T_{TAB} = 25^\circ C$, $R_L = 8\Omega$, $A_V = 50$ (34 dB), unless otherwise specified.

PARAMETER	CONDITIONS	MIN	TYP	MAX	UNITS
Total Supply Current	$P_{OUT} = 0W$		15	65	mA
	$P_{OUT} = 1.5W/Channel$		430		mA
DC Output Level			14		V
Supply Voltage		10			V
Output Power	T.H.D. = 5%		6		W
	T.H.D. = 10%	6	7		W
T.H.D.	$P_{OUT} = 1W/Channel$, $f = 1 kHz$		0.07	1	%
	$P_{OUT} = 4W/Channel$, $f = 1 kHz$		0.2		%
Offset Voltage			15		mV
Input Bias Current			100		nA
Input Impedance		3			M Ω
Open Loop Gain	$R_S = 0\Omega$	66	90		dB
Channel Separation	$C_F = 250\mu F$, $f = 1 kHz$	50	70		dB
Ripple Rejection	$f = 120 Hz$, $C_F = 250\mu F$		70		dB
Current Limit			1.5		A
Slew Rate			1.4		V/ μs
Equivalent Input Noise Voltage	$R_S = 600\Omega$, 100 Hz - 10 kHz		3		μV_{rms}

Note 1: For operation at ambient temperatures greater than 25°C the LM379 must be derated based on a maximum 150°C junction temperature using a thermal resistance which depends upon device mounting techniques. In most applications it is advisable to heat sink to the chassis. See curves.

Typical Performance Characteristics

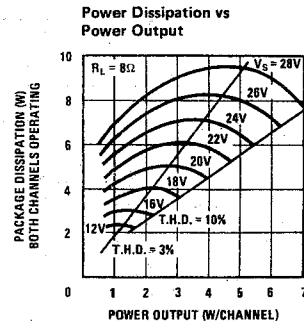
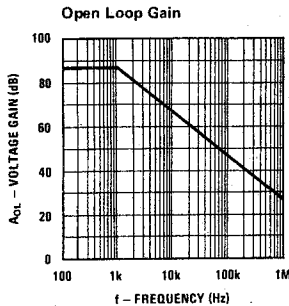
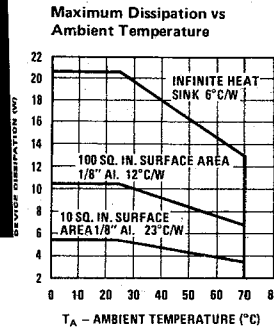

Typical Performance Characteristics (Continued)

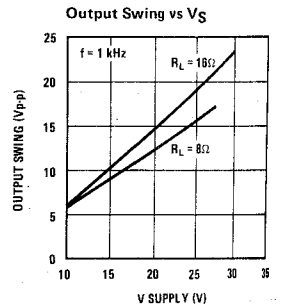
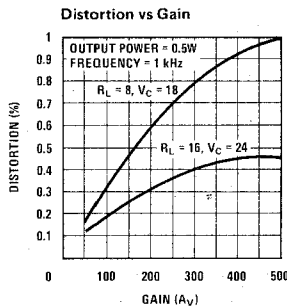
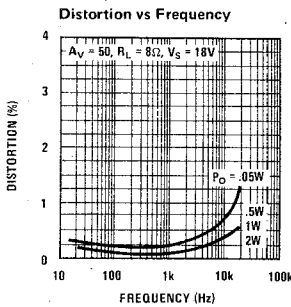
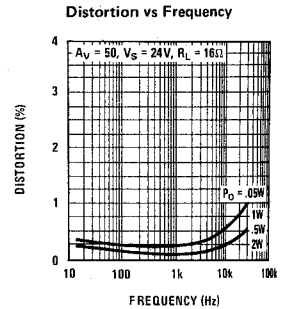
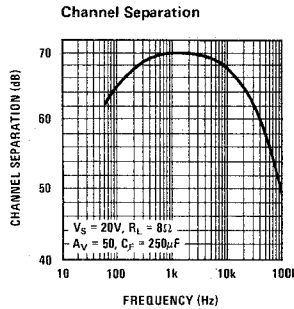
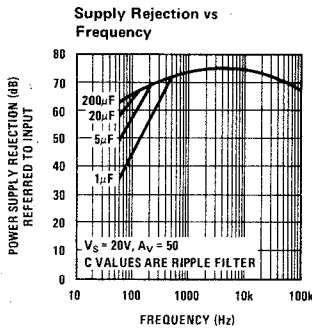
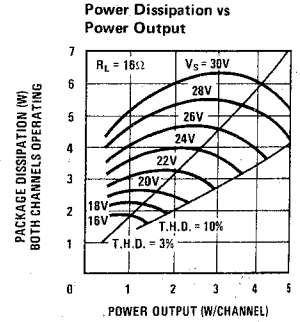
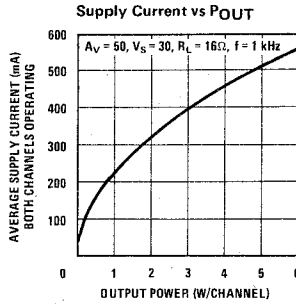
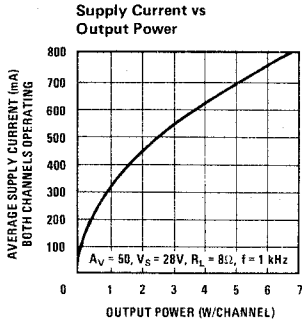

Typical Applications (Continued)

Two-Phase Motor Drive

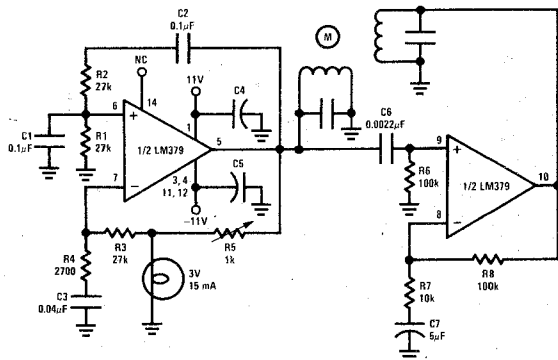

12W Bridge Amplifier

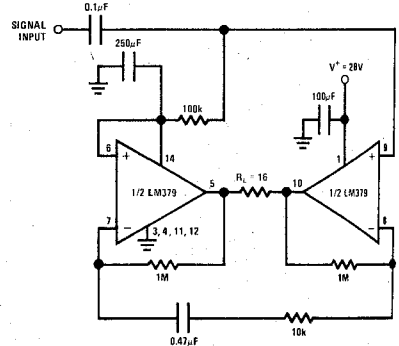

Typical Applications (Continued)

Simple Stereo Amplifier with Bass Boost

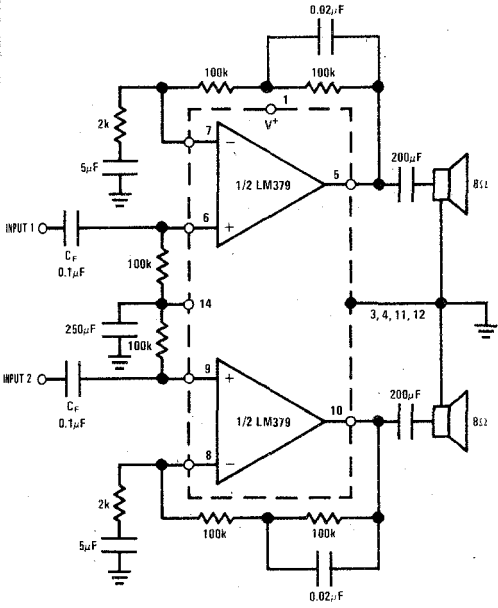

Power Op Amp (Using Split Supplies)

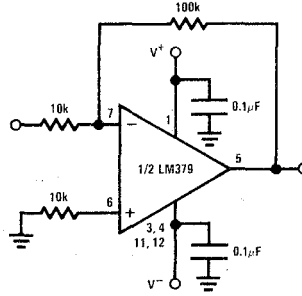

LM379

10